

Series 900 Reduced Pressure Zone Assemblies

Sizes: 2" through 6"

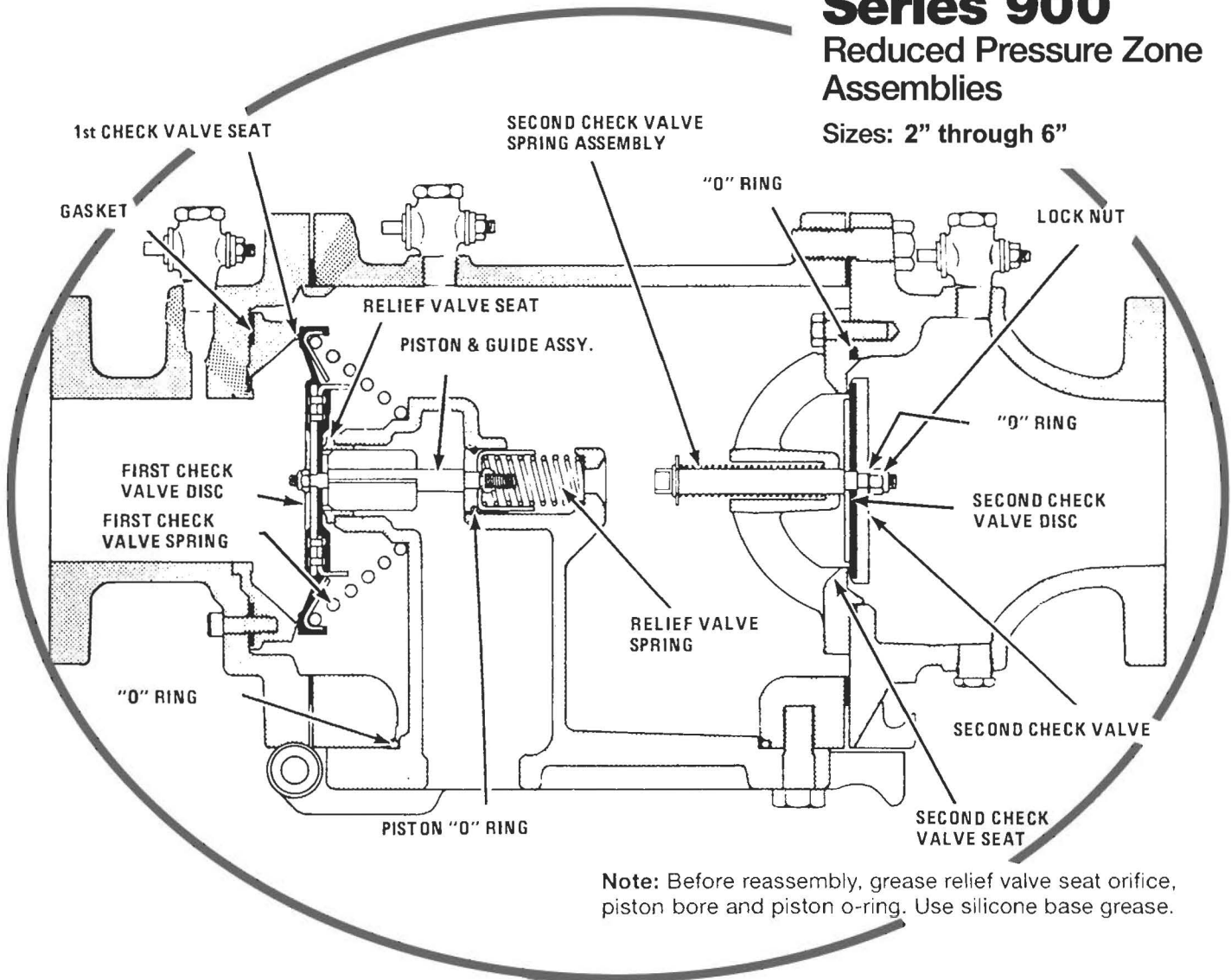

Note: Before reassembly, grease relief valve seat orifice, piston bore and piston o-ring. Use silicone base grease.

REPAIR KITS

EDP No.	Kit No.	Size	EDP No.	Kit No.	Size
First Check Assembly Kits:			Rubber Parts Kits:		
889100	36 BFP-RK	2½", 3"	881295	42 BFP-RK	2½", 3"
889110	37 BFP-RK	4"	881297	43 BFP-RK	4"
889120	38 BFP-RK	6"	881298	44 BFP-RK	6"
Second Check Assembly Kits:			Series 900 Maintenance Tool Kits:		
889105	39 BFP-RK	2½", 3"	834019	SAT900H153	2½", 3"
889115	40 BFP-RK	4"	834042	SAT900J153	4"
889125	41 BFP-RK	6"	834018	SAT900K153	6"

Kit consists of: first check valve seat and disc, valve spring, gasket, relief valve seat and spring.

Kit consists of: first check valve disc, second check valve disc, o-rings and silicone grease.

Kit consists of: second check valve spring assy, valve disc and seat, o-rings, lock nut, piston o-ring and guide assy, and relief valve o-ring.

American Backflow Specialties

www.americanbackflow.com

(800) 66-BKFLO

(619) 527-2525

Fax: (619) 527-2527